

Machines and service

- Gelcoat application
- Resin chopper application
- Bonding paste application
- Injection processes
- Laminating roll unit
- Metering devices
- Distillation
- Stirring and mixing equipment
- Construction of special machines
- BÜFAtec service

BÜFAtec GmbH & Co. KG
Hohe Looge 2-8
26180 Rastede
GERMANY
Phone +49 4402 975-0
Fax +49 4402 975-300
buefatec@buefa.de
www.buefa.com
www.buefatec.com

A member of the BÜFA group

The information given above is based on our current state of knowledge and experience. In view of the many factors that may influence working conditions and the application of our products, the user is not relieved from carrying out his own tests and experiments. Not legally binding warranty of certain properties or suitability for a particular purpose can be derived from this information. It is the responsibility of the receiver or user of our products to observe proprietary rights as well as existing laws and regulations.

You'll find further information at www.buefatec.com

Polycon

For spraying gelcoats and fillers



Gelcoat application

BÜFAtec Spray gun Polycon



Gelcoat application

Greatest possible flexibility through nine nozzle sizes and two container sizes, making it suitable for practically all types of gelcoats with the most different viscosities.

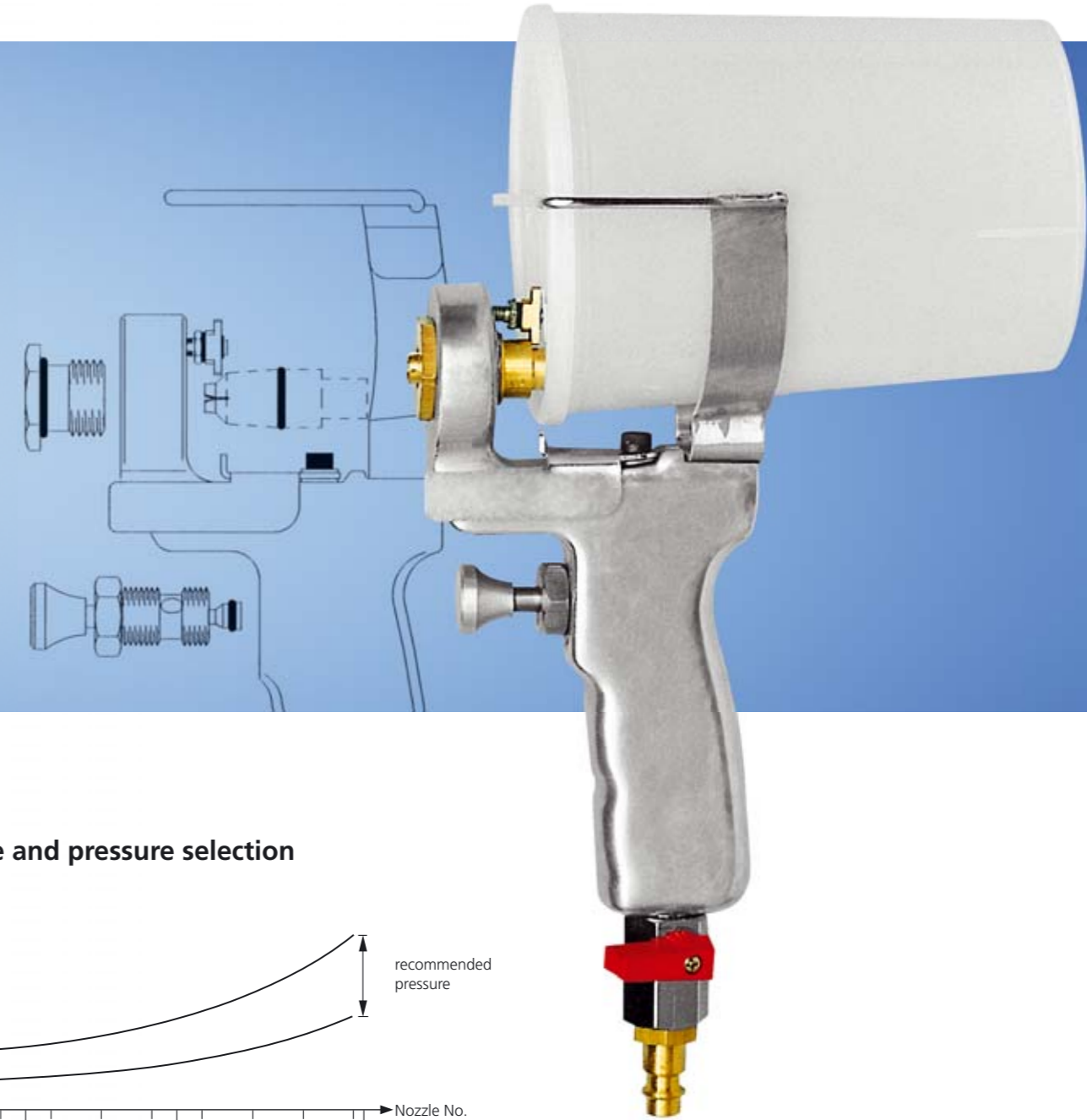
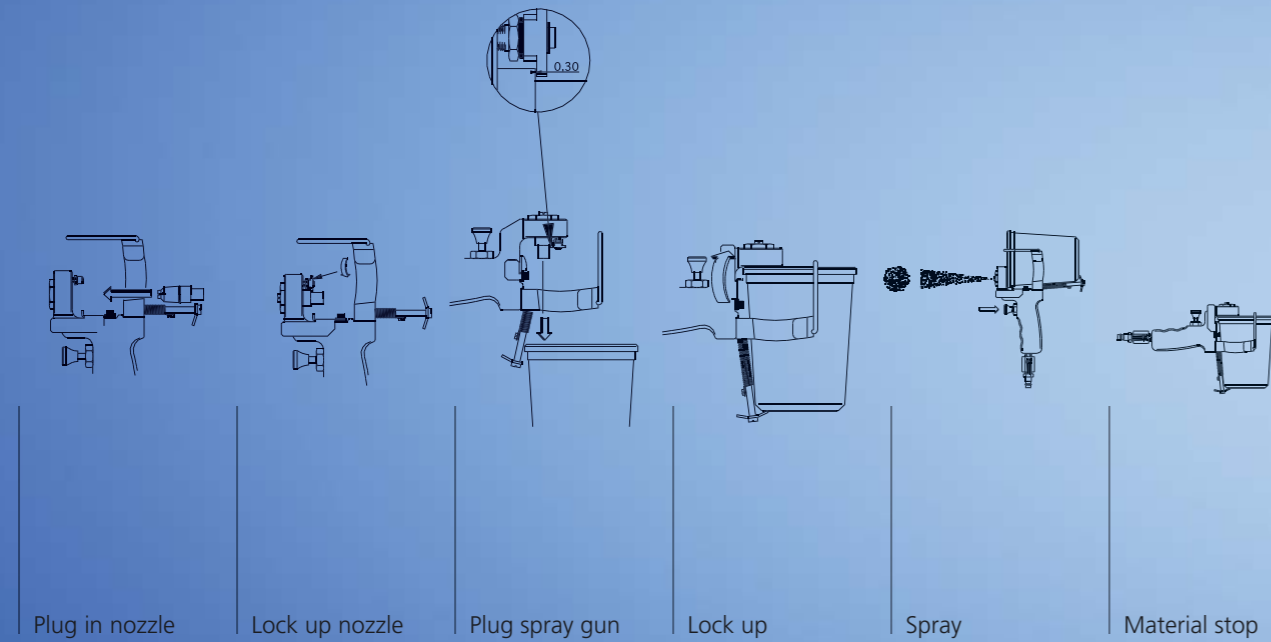

The Polycon spray gun uses a selection of plug-in nozzles and plug-in containers. A short, straight fluid passage, self-releasing polypropylene containers and the gun's no-nonsense design eliminates clogging and clean up problems. Nine sizes of nozzles and two sizes of containers give total flexibility for size of job, rates of application and various gelcoat viscosities.

Facts

- quick colour change
- low cost
- easy to use
- easy to clean and maintain
- fast, uniform coating
- industry standard for 20 years

Accessories

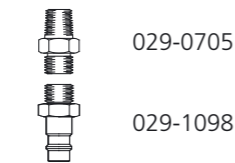

029-0705

029-1098

Polycon nozzle set (9 nozzles)
Product No. 026-0301

Nozzles (single)

0,8 Ø	Polycon nozzle No. 1	Product No. 026-0341
1,6 Ø	Polycon nozzle No. 2	Product No. 026-0342
2,4 Ø	Polycon nozzle No. 3	Product No. 026-0343
3,2 Ø	Polycon nozzle No. 4	Product No. 026-0344
4,0 Ø	Polycon nozzle No. 5	Product No. 026-0345
4,8 Ø	Polycon nozzle No. 6	Product No. 026-0346
5,6 Ø	Polycon nozzle No. 7	Product No. 026-0347
6,4 Ø	Polycon nozzle No. 8	Product No. 026-0348
7,2 Ø	Polycon nozzle No. 9	Product No. 026-0349

Container

Container size 1.0 litre	Product No. 026-0324
Lid for container 1.0 litre	Product No. 026-0327
Container size 2.5 litre	Product No. 026-0326
Lid for container 2.5 litre	Product No. 026-0325

Bow

Bow for 1.0 litre container	Product No. 026-0310
Bow for 2.5 litre container	Product No. 026-0330

Nozzle and pressure selection

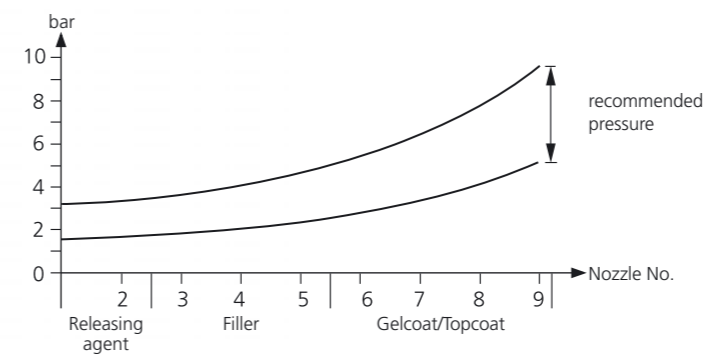

Specifications

Material	Aluminium
Air requirements (gelcoat)	max. 3.5 l/min.
Air pressure	3.5 - 7 bar
Air consumption	400 - 800 l/min
Weight	0,5 kg
Air connection	single hand coupler NW 7 (filtered air)

BÜFAtec Spray gun Polycon Product No. 026-0300